

# US-ES 931HCW / US-ES 933HCW

Vandal resistant substation

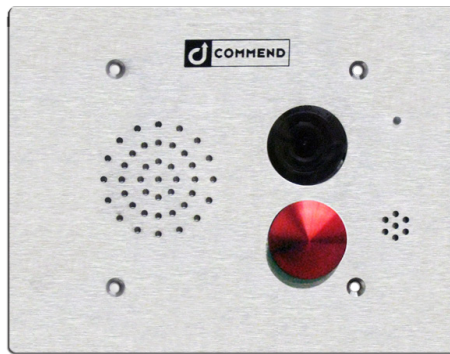
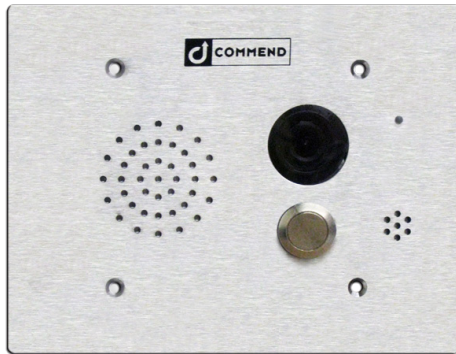

HD  
Audio

2  
Versions

IP  
Networks

LED  
Colors

## US-ES931HCW / US-ES933HCW - Intercom Substation

The 3 Gang Hybrid SIP/IoIP (Intercom over IP) is easy to operate and provides clear intelligibility under all ambient conditions. Permanent function monitoring ensures in-service status of the system. The 3 mm stainless steel front panel with poke protection and special screws offers optimal protection against vandalism. The Intercom station series US-ES 931HCW / US-ES 933HCW is designed especially for mounting in American "3-Gang" boxes.

### Features and Highlights

#### US-ES931HCW

- High volume capacity and superior speech quality, thanks to integrated 10 watt class-D amplifier and eHD Voice
- Compact and vandal resistant construction enables use in public areas
- Stainless steel button (US-ES 931HCW) or red mushroom button (US-ES 933HCW) for emergency calls, with self-checking functionality (NC contact)
- Cyclical connectivity and function checks ensure permanent availability of all functions and low manual maintenance requirements
- Special audio functions ensure superior speech quality in any situation
- The high-sensitivity microphone supports speaking distances of up to 7 m, making the device ideally suited, e.g. for wheelchair users
- Sound output or playback of pre-recorded messages can be used to provide information and reassurance to callers
- Fully PoE powered
- Ready for connection of induction loop systems, which enables persons wearing hearing aids with an induction loop to receive Intercom audio signals in clear, uninterrupted quality
- Integrated I/Os for connection of door openers etc.

#### US-ES933HCW

- Version with red mushroom button

#### US-ES3GBB

- 3 gang switch / backbox
- Powder coated gray

#### US-ES3GRH

- 3 gang rain hood
- Powder coated gray



# Features and highlights

Gasket for poke protection, and weather resistance

Tricolor LED

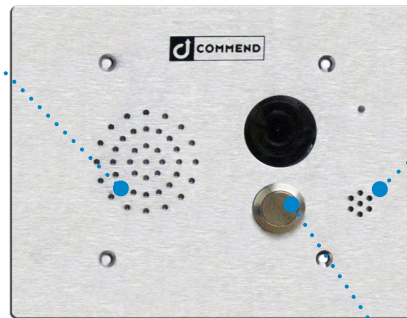

HD audio, 16 kHz with IoIP / 7 kHz with SIP

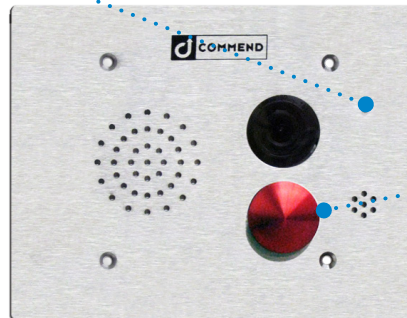

Available with silver or red mushroom button

## Benefits

- Communication via data networks- no additional cabling required
- Crystal clear speech quality for optimum intelligibility
- Integration in existing housings and panels
- Connection possibilities for-
  - Microphone and loudspeaker
  - Multiple tamper resistant call buttons
  - IP-devices (IP-camera, parking terminals, etc.)
  - LED for indication of conversations
- Inputs and outputs for control and indication functions e.g. control of barriers
- Local power supply or POE (intercom module only)
- In case of a changing public IP-address, dynamic registration is possible
- Supports DSP-functionilities such as Open Duplex®, Audio Monitoring, Loudspeaker-/Microphone Surveillance, etc.
- Option boards offer additional powerful features
- Line input for feed-in of audio
- Configurable Ethernet parameters
- Easy administration via intercom server configuration

## Features

- Direct network connection with Static IP or DHCP
- Full open duplex communications
- Power over Ethernet (POE) supported
- Rugged 11 gauge stainless steel faceplate
- True tamper resistant construction
- Rugged call button
- Weather resistant
- Sensitive electret microphone
- Mounts in industry standard 3 gang switch / backbox
- Mic Open LED
- Full Supervision (speaker, microphone, station electronics, cable, network)
- Wide angle camera (up/down angle adjustable)

# US-ES931HCW / US-ES933HCW

## Technical Specifications

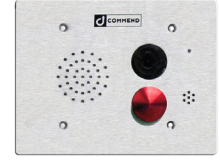
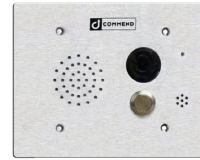

### Technical Data US-ES931HCW / US-ES933HCW with ET-908H Intercom Module

<b>Operating temperature range:</b>	-40 °C to +70 °C (-40 °F to +158 °F) <sup>1)</sup>
<b>Storage temperature range:</b>	-40 °C to +70 °C (-40 °F to +158 °F) <sup>1)</sup>
<b>Relative Humidity:</b>	up to 95% not condensing
<b>Microphone input:</b>	possibility for connection of an electret condenser microphone or a dynamic microphone electret condenser microphone: nominal -43 dB/Pa (feeding voltage: 2.5 V at 3.3 kΩ)
<b>Loudspeaker output:</b>	10 W at 4 Ω/6 W at 8 Ω max. 6.3 V <sub>eff</sub> (volume level "11")
<b>Ext. microphone, loudspeaker:</b>	possibility for connection of e.g. a headset/handset EP output: max. 880 mV <sub>eff</sub> (volume level "11"), R <sub>i</sub> = 200 Ω EM input, nominal level: 14 mV on 3.3 kΩ (feeding voltage 2.5 V)
<b>Line input:</b>	for feed-in of audio (e.g. music, radio conference) nominal level 0 dBu (0.775 V) at 10 kΩ
<b>Amplifier:</b>	Built-in amplifier class "D" with 2.5 W
<b>Inputs:</b>	3 inputs for floating contacts (IoIP: detection of 5 input states)
<b>Outputs:</b>	2 relay outputs (switch-over contacts) max. 60 W (DC)/37.5 VA (AC) max. 2 A max. 60 VDC/30 VAC expected life: min. 5 x 10 <sup>4</sup> (2 A), 10 <sup>5</sup> (1 A)
<b>Frequency range:</b>	50 - 16,000 Hz (depending on connected loudspeaker)
<b>Connection:</b>	spring clamp terminals (conductor cross-section: 0.2 – 1.5 mm <sup>2</sup> ) expansion plug, e.g. for EB2E2AHE shielded RJ45 modular jacks
- IP Uplink/Downlink:	
<b>Device class:</b>	ES1, PS2 as per IEC/EN 62368-1 UL 62368-1 and CAN/CSA C22.2 No. 62368-1-14, Audio/video, information and communication technology
<b>Cabling:</b>	min. shielded Ethernet Cat. 5
<b>Power supply:</b>	24 VDC (15 – 28 VDC), max. 1 A or PoE
<b>PoE (power over ethernet):</b>	following IEEE 802.3af power consumption of the terminal device: 36 – 57 V, 15.4 W, Class 0 (0.44 to 12.95 W)
<b>Protocols (IoIP):</b>	IoIP-Protocol based on UDP/IP
<b>Protocols (SIP):</b>	IPv6, IPv4, TCP, UDP, HTTP (RFC 2617, RFC 3310), RTP (RFC 3550), RTCP, DHCP, SDP (RFC 2327), SIP (RFC 3261), SNMPv2, STUN, TFTP, URI (RFC 2396), DTMF Decoding (RFC 2876, RFC 2833), SIP User Agent (UDP RFC 3261), SIP Refer Method (RFC 3515)
<b>Codecs (SIP):</b>	G.711 a-Law, G.711 μ-Law, G.722
<b>Data rate:</b>	2 x 10/100 MBit/s (Full/Half Duplex) auto MDIX
<b>Measurements:</b>	6.56 in x 4.93 in
<b>Weight:</b>	about 220 g (0.5 lbs)

<sup>1)</sup> Temperature range for MIC 480: -20 °C to +70 °C (-4 °F to +158 °F)

### System requirements

#### IoIP

##### Intercom Server

- GE 800 (min. PRO 800 6.3) with G8-IP (min. version 6.6A) or
- GE 300 (min. PRO 800 6.3) with G3-IP (min. version 6.6A) or
- IS 300/G8-IP-32 (min. PRO 800 6.3, min. version 6.6A) or
- S3/S6/VirtuoSIS (min. version 7.1)

##### Configuration software

- CCT 800 (min. version 7.1)
- IP Station Config (included in setup of CCT 800)

#### SIP

- Compatible SIP server (see page TE | 2) or
- S3/S6/VirtuoSIS (min. version 7.1) or
- GE 800 with G8-VOIPSERV or
- Serverless operation

#### Device firmware

- IoIP-Device (min. version 7.2)
- SIP Series (min. version 3.8.1, build 61)

#### All connected circuits shall fulfill the following requirements:

- Safety Extra Low Voltage (SELV) and Limited Power Source (LPS) according to IEC/EN 60950-1 or
- ES1, PS2 circuits and Annex Q (Limited Power Source) according to IEC/EN/UL 62368-1
- UL 62368-1 and CAN/CSA C22.2 No. 62368-1-14, Audio/video, information and communication technology

#### ATTENTION:

- Downgrading to firmware version SIP Series 3.9 build 24 or lower is not supported.

### Requirements to the network

#### IP addresses and ports

- For the Product name (variable), the DHCP functionality is available. If DHCP is not used, the Product name (variable) must have a fixed IP address.
- In case of a changing public IP address, dynamic registration of a Product name (variable) is possible.
- Communication from the program IP Station Config is done via port 16399 (cannot be configured).
- Communication from the Product name (variable) to the Intercom Server (UDP protocol) is done via port 16400 (configurable).

#### QoS requirements

- Maximum one-way-delay 100ms
- Delay-Jitter not above 50ms
- 0% packet loss for perfect audio quality

#### Bandwidth

- Required bandwidth incl. protocol overhead per Product name (variable), for upload and download each, speech and data: 96 kBit/s
- Speech is compressed according to G.722 standard.

### Line length in LAN

The maximum line length of Cat. 5 cabling in a LAN is 100 m (328 ft) – e.g. from switch to Intercom station.

# US-ES931HCW / US-ES933HCW

## Camera Data

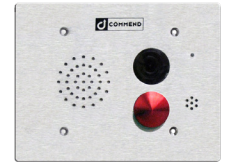
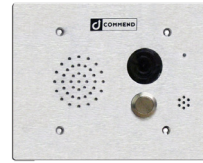

### Technical data - Axis Camera

Camera	
<b>Image Sensor</b>	Progressive scan RGB CMOS 1/2.8"
<b>Lens</b>	M12 mount, Fixed iris, Megapixel resolution 3.6mm, F2.0,
<b>Horizontal angle of view:</b>	87°
<b>Vertical angle of view:</b>	47°
<b>Diagonal angle of view:</b>	102°
<b>Minimum Illumination</b>	Color: 0.2 lux
<b>Shutter Time</b>	
<b>Power line frequency 50 Hz:</b>	1/28000 s to 2 s
<b>Power line frequency 60 Hz:</b>	1/33500 s to 2 s
<b>Camera angle adjustment</b>	Pan ± 30°, Tilt 15-90°, Rotation ± 175°
Video	
<b>Video compression</b>	H.264 (MPEG-4 Part 10/AVC) Main and Baseline profiles motion jpeg
<b>Resolutions</b>	1920 x 1080 to 160 x 90
<b>Frame Rate</b>	Up to 30 fps in all resolutions
<b>Video Streaming:</b>	Multiple, individually configurable streams in H.264, Motion jpeg controllable frame rate and bandwidth, VBR/CBR H.264
<b>Image Settings</b>	Compression, Color, Brightness, Sharpness, Contrast, White Balance, Exposure Control, Exposure zones, Backlight compensation, Fine tuning of behavior at low light, wide dynamic range-dynamic contrast, text and image overlay, privacy mask, mirroring of images, traffic light mode Rotation: 0°, 90°, 180°, 270° including corridor format
Network	
<b>Security</b>	Password protection, IP address filtering, HTTPS <sup>a</sup> encryption, IEEE 802.1X <sup>a</sup> network access control, Digest authentication, user access log, centralized certificate management
<b>Supported Protocols</b>	IPv4/v6, HTTP, HTTPS <sup>a</sup> , SSL/TLS <sup>a</sup> , QoS layer 3 DiffServ, FTP, CIFS/SMB, SMTP, Bonjour, UPnP <sup>TM</sup> , SNMP v1/v2c/v3 (MIB-II), DNS DynDNS, NTP, RTSP, RTP, SFTP, TCP, UDP, IGMP, RTCP, ICMP, DHCP, ARP, SOCKS, SSH

### System Integration

<b>Application Programming Interface</b>	Open API for software integration, including VAPIX <sup>®</sup> and AXIS camera application platform; specifications at <a href="http://www.axis.com">www.axis.com</a> AXIS video hosting system (AVHS) with One-Click Connection ONVIF profile S, specification at <a href="http://www.onvif.org">www.onvif.org</a>
<b>Analytics</b>	Video motion detection, active tampering alarm, AXIS camera application platform enabling installation of additional applications
<b>Event triggers</b>	Analytics, time scheduled, edge storage events
<b>Event actions</b>	
<b>File upload:</b>	FTP, SFTP, HTTP, HTTPS, Email
<b>Notification:</b>	Email, HTTP, HTTPS and TCP Video recording to edge storage, Pre- and Post-alarm video buffering, status LED activation
<b>Power</b>	Power over Ethernet IEEE 802.3af/802.3at Type 1 Class 2, max. 4.1 W
<b>Connectors</b>	
<b>RJ-45:</b>	Male RJ45 10BASE-T/100 BASE-TX
<b>M12:</b>	Male, D-coded M12 connector with rotatable coupling nut All connectors support Power over Ethernet
<b>Video management software</b>	AXIS camera companion, AXIS camera station, video management software from AXIS' application development partners available on <a href="http://www.axis.com/techsup/software">www.axis.com/techsup/software</a>

## Requirements to the network for use as SIP device

### Ports

- The configuration via the web interface is done via TCP port 80 (cannot be configured).
- The communication from the SIP device to the SIP server is done via the following ports (both are configurable):
  - SIP: UDP port 5060
  - RTP: UDP port 16384 (incoming)

## Requirements to the network for use as VoIP device

### IP addresses and ports

- For the ET 908H, the DHCP functionality is available. If DHCP is not used, the ET 908H must have a fixed IP address.
- In case of a changing public IP address, dynamic registration of an ET 908H is possible.
- Communication from the program IP Station Config is done via port 16399 (cannot be configured).
- Communication from the ET 908H to the Intercom Server (UDP protocol) is done via port 16400 (configurable).

### QoS requirements

- One-way delay max. 100 ms
- Delay jitter max. 50 ms
- 0% packet loss for perfect audio quality

### Bandwidth

For further information on bandwidth, see guideline "VoIP Technology"

## Compatibility SIP PBX

Generally, the SIP device can be used with any SIP server.

The following server types have been tested explicitly by Commend and therefore a proper functionality can be confirmed:

Manufacturer <sup>1)</sup>	Type	Version
Cisco	Cisco Call Manager Cisco Unified Communication Manager	Versions 5, 6, 7, 8, 9
Digium	Asterisk	Versions 1.2, 1.4, 1.6
Avaya (former: Nortel)	CS1000	Version 6
Avaya	Avaya Aura™ (Avaya Communication Manager, Avaya Session Manager)	Release 6.1
Innovaphone	Virtual Appliance IPVA	Version 9 final
Alcatel	OmniPCX Enterprise (DXE)	Release 9
Siemens	Hipath 4000 Hipath 3000 + HG 1500	Version 5
3CX	3CX for Windows	3CX PhoneSystem Versions 9, 10, 11
Starface	Starface free	Versions 4.x, 5.x
Aastra (former: Ericsson)	MX-ONE	Version 4.1 SP 1
Kamailio	Kamailio (OpenSER)	Version 3.3.0
FreeSWITCH	FreeSWITCH	Version 1.1 Beta1
ELMEG	elmeg ICT880	Version 7.67D
2N®	2N® Netstar IP	Version 3.1.0.96
AVM	Fritz!Box Fon 7170 Fritz!Box Fon 7270	Version 29.04.87 Version 54.05.05
Sipgate	sipgate.de	tested in Dec 2010
Vodafone Arcor	vodafone.de	tested in Jan 2011
blue SIP	blueSIP.net	tested in May 2011
Mitel	3300ICP	12.0.0.49

<sup>1)</sup> The listed products and company names are brand names or registered trademarks of their respective owners.

# US-ES931HCW / US-ES933HCW Installation Instructions

## Precautions / Wall Mounting info

- When opening the stations ESD precautions must be observed.
- The stations may only be opened by authorized service engineers.
- Do not expose the station to extreme temperature (below -40°C or above +70°C / -40°F to +158°F).
- The stations are designed especially for building into American "3 gang" double deep switch boxes. Box and mounting screws are not included in the extent of supply.
- For stations to be mounted in outdoor areas, the screws must be closed with a sealing compound.

## Dimensions side panel

Measuring units in inches, not to scale!

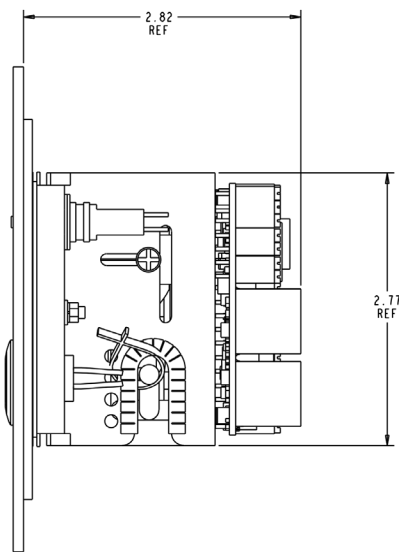

## Dimensions front panel

Measuring units in inches, not to scale!

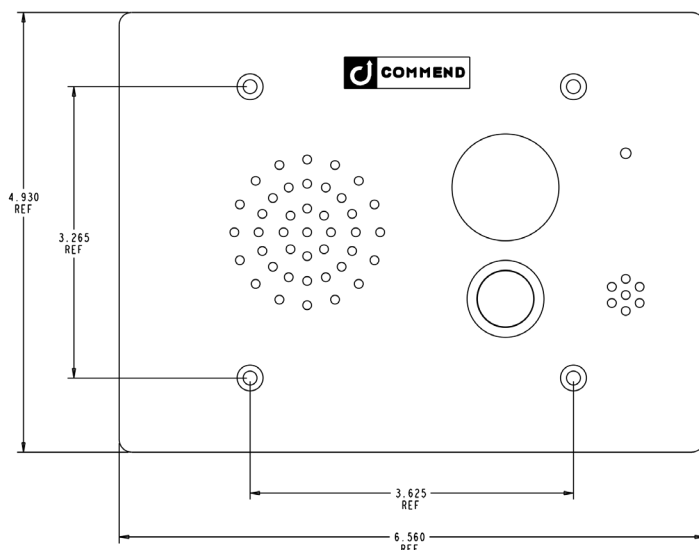

## Extent of supply

- Intercom terminal

## Dimensions top panel

Measuring units in inches, not to scale!

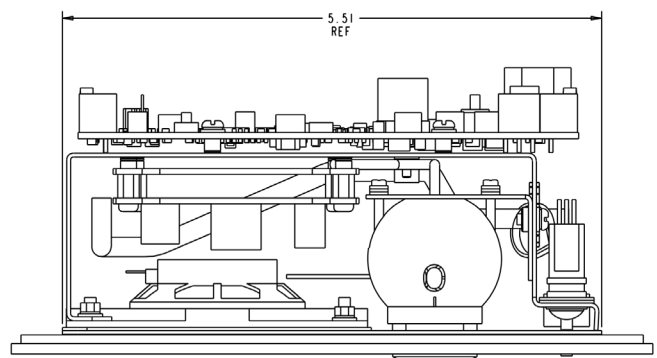

## AutoCad circuit board

Drawing not to scale!

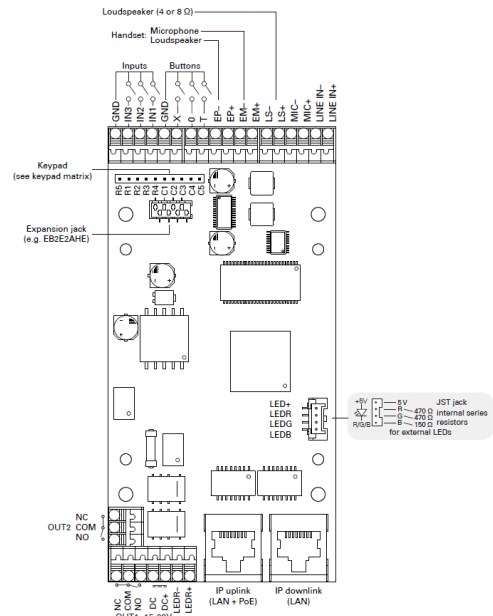

### Note:

For barrier-free operation, it is recommended to mount the station to walls or corners with enough space.