

US-CSH-06-S

Stainless Steel Security Housing



Interior /
Exterior

High
Visibility

Vandal
Resistant

Customizable

Vandal-Resistant Hardware

The US-CSH-06-S security wall housing is designed to house Commend's tamper/weather resistant substations in either interior or sheltered exterior locations. Both the size and optional high visibility colors provide an extremely visible and aesthetic security site for people in duress. The housing is constructed of stainless steel which is then optionally painted in a variety of durable finishes. This provides reliable and attractive housing for the Commend security substation. The US-CSH-06-S can be configured to accept a variety of Commend security substations.

Functions and highlights

Wall-mount housing

- Height: 12.75"
- Width: 9.5"
- Depth: 3.48"
- Weight: 11 lbs
- Stainless steel thickness: 0.06"

Optional Features

- Clear coat enclosure for additional protection
- Standard or custom finish color
- Pole mount kit
- Curb mount stand
- Combination LED blue beacon and strobe kit (low voltage)

Technical Data and System Requirements

Depending on desired Intercom (consult with Commend Americas sales for support).

Connection Diagram

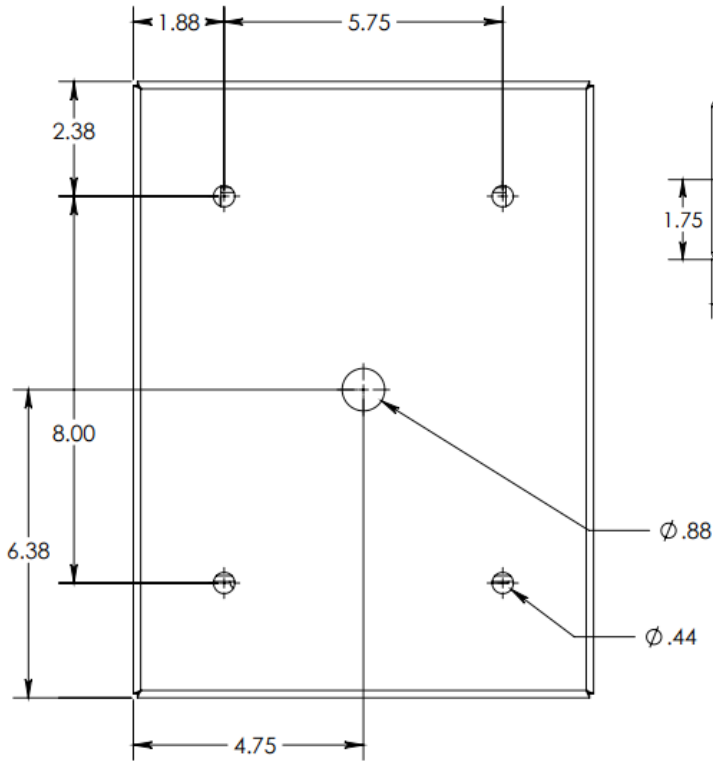

Precautions

- When opening the stations ESD precautions must be observed.
- The stations may only be opened by authorized service engineers.

Extent of Supply

- 1 security housing
- Installation screws

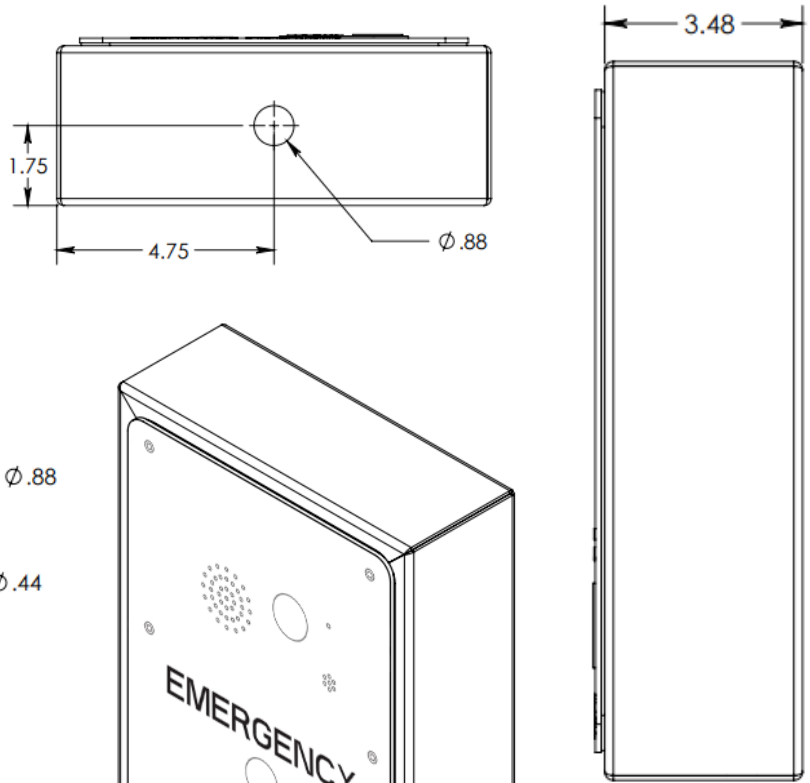

Color Choices



Applications

- Hospitals
- Parking garages
- Airports
- Jails / Correctional Facilities
- Toll booths / tunnels
- Schools / campuses
- Apartment complexes
- Mass transit

Benefits

- High visibility
- Weather / Vandal resistant
- Trim rings available to fit smaller substations
- Ideal for people in duress
- Attractive and durable housing
- Mass notification reliability
- Scream alarm feature in Commend Stations
- Separate strobe is available