

AF 50I

Compact 50-watt IP amplifier



Easy
integration

Loudspeaker
line
monitoring

Rugged
housing

Fully
IP-based

Flexible amplification

The series AF 50 provides a particularly high output range and various loudspeaker outputs. These amplifiers are universally suitable for any size of application up to complex public address and Intercom solutions. They are specifically optimised for installation either in a 19" rack or on site. This helps to save on cabling and any costs incurred.

The range of application environments is suitably flexible as well: serving the public address needs from public service facilities (e.g. railway stations) to auditoriums or waiting rooms and covering the Intercom requirements of noisy industrial facilities, garages, tunnels or office buildings.

Features and highlights

- 50 watts of output power
- Output for low-resistance loudspeakers and for 70 V/100 V loudspeakers
- Class-D amplifier, optimised for high efficiency at low operating temperatures
- Protection against short circuits and overranges
- Line monitoring between amplifier and Intercom Server
- Loudspeaker line monitoring at the 70 V/100 V loudspeaker output (requires licence "L-AF-LM")
- 16 kHz transmission bandwidth for highest speech intelligibility
- Easy integration into existing Intercom systems
- High level of reliability
- Supports Intercom station features (e.g. line monitoring, function monitoring and DSP tone)
- Single or double mount in a 19" rack or on site
- Rugged housing made of polycarbonate

AF 501

Technical specifications



Technical data

IP rating:	IP20 (acc. EN 60529)
Output power:	50 W (RMS)
Loudspeaker outputs:	low-resistance (min. impedance: 4 Ω) or 70 V/100 V
Microphone input:	nominal level: 14 mV at 3.3 kΩ microphone supply voltage: 2.5 V
Line output:	nominal level: 0 dBu (0.775 V)
Inputs:	2 inputs for floating contacts (detection of 5 input states)
Control input:	0–10 V (for remote volume control)
Output:	relay output (changeover contact): 30 V/1 A 100,000 switch cycles
Protocol:	IoIP, based on UDP/IP
Frequency response:	50 Hz to 15 kHz (–3 dB)
Total harmonic distortion (THD+N):	4 Ω, 8 Ω: < 0.2% 70 V/100 V: < 1% at 50 W/< 0.4% at 35 W
Operating temperature range:	–25 °C to +55 °C (–13 °F to +131 °F)
Storage temperature range:	–25 °C to +70 °C (–13 °F to +158 °F)
Relative humidity:	up to 95%, not condensing
Connections:	2 RJ45 modular jacks with LEDs for connection to the Intercom Server (IP Uplink, IP Downlink) pluggable screw terminals (0.08 mm ² –1.5 mm ²): power supply, outputs, microphone, inputs, line output, 70 V/100 V loudspeaker output pluggable screw terminals (0.08 mm ² –2.5 mm ²): low-resistance loudspeaker output expansion plug for e.g. EB2E2A
Power supply:	20–26 VDC ¹⁾ (max. 2.6 A at 4 Ω/50 W or max. 1.3 A at 8 Ω/25 W, max. 3 A at the 70 V/100 V loudspeaker output) or PoE ²⁾
PoE (Power over Ethernet):	IEEE 802.3af standard power consumption terminal device: class 0 (0.44 W to 12.95 W)
Cabling:	min. Cat. 5
Dimensions (W x H x D):	201 x 44 x 255 mm (7.91 x 1.73 x 10.04 in)
Weight incl. package:	1,600 g (3.53 lbs)

¹⁾ For a faultless operation, an earthed power supply unit is recommended, e.g. PA60W24V.

²⁾ If power supply over PoE is used, an attenuation of up to 12 dB is possible. This is equal to an output power of 6 W.

Line length

Intercom Server to amplifier

The maximum line length of Cat. 5 cabling in a LAN is 100 m (328 ft) – e.g. from switch to amplifier.

Amplifier to loudspeaker

It is recommended to select the line length between the low-resistance loudspeaker output of the amplifier and loudspeaker as short as possible.

Cable diameter	Line length at loudspeaker impedance	
	4 Ω	8 Ω
∅ 0.5 mm (AWG: 24)	10 m (32.8 ft)	20 m (65.6 ft)
∅ 0.6 mm (AWG: 22)	14 m (45.9 ft)	28 m (91.9 ft)
∅ 0.8 mm (AWG: 20)	24 m (78.7 ft)	48 m (157.5 ft)
∅ 1.0 mm (AWG: 18)	37 m (121.4 ft)	73 m (239.5 ft)
∅ 1.4 mm (AWG: 15)	73 m (239.5 ft)	146 m (479 ft)
∅ 1.8 mm (AWG: 13)	122 m (400 ft)	244 m (800 ft)

The specified line length corresponds to a halving of the performance of the loudspeaker or –3 dB voltage drop.

Extent of supply

- Amplifier
- Short reference

NOTE:

The power supply is not included in extent of supply.

System requirements

Intercom Server

- GE 800 (min. PRO 800 1.3 build 9) with G8-IP (min. G3-8-IP 4.2) or
- GE 300 (min. PRO 800 1.3 build 9) with G3-IP (min. G3-8-IP 4.2) or
- GE 700-UPG (min. PRO 800 1.3 build 9) with G7-DSP-IP or
- GE 700 (min. Pro 6.0) with G7-DSP-IP ¹⁾ or
- GE 200 (min. Pro 6.0) with G2-DSP-IP ¹⁾

¹⁾The AF 50I is detected as an ET 908. Therefore, it can only be used with the feature scope of an ET 908. The firmware download is only possible with a GE 700-UPG or via IP Station Config.

Configuration software

- min. CCT 800 1.3 (build 935)

Network requirements

IP addresses and ports

- For the AF 50I, the DHCP functionality is available. If DHCP is not used, the AF 50I must have a fixed IP address.
- In case of a changing public IP address, the dynamic registration of a AF 50I is possible.
- Communication from the software IP Station Config is done via port 16399 (cannot be configured).
- Communication from the AF 50I to the Intercom Server (UDP protocol) is done via port 16400 (configurable).

QoS requirements

- One-way delay max. 100 ms
- Delay jitter max. 50 ms
- 0% packet loss for perfect audio quality

Bandwidth

- Required bandwidth incl. protocol overhead per AF 50I, for upload/download each speech and data (no video): 96 kBit/s
- Speech is compressed according to G.722 standard.

System overview

The following illustration shows an example of the integration of an AF 50I amplifier into an IP network.

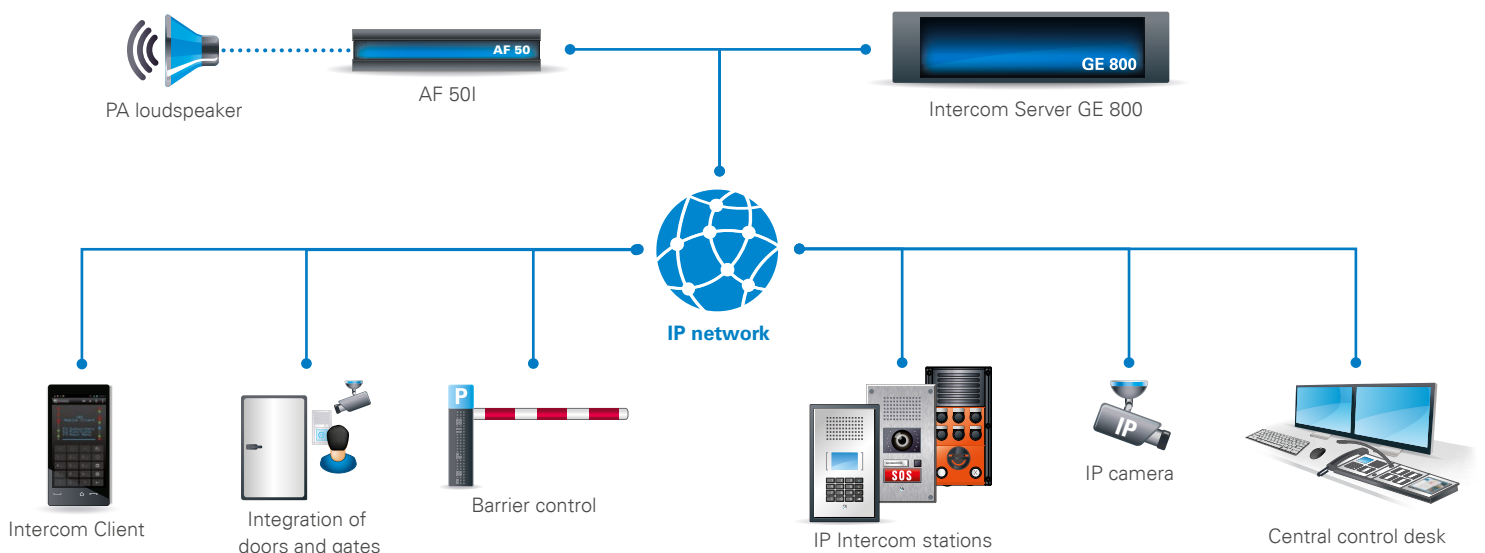

AF 50I

Installation instructions

Dimensions front panel

Measuring units in mm (in), not to scale!

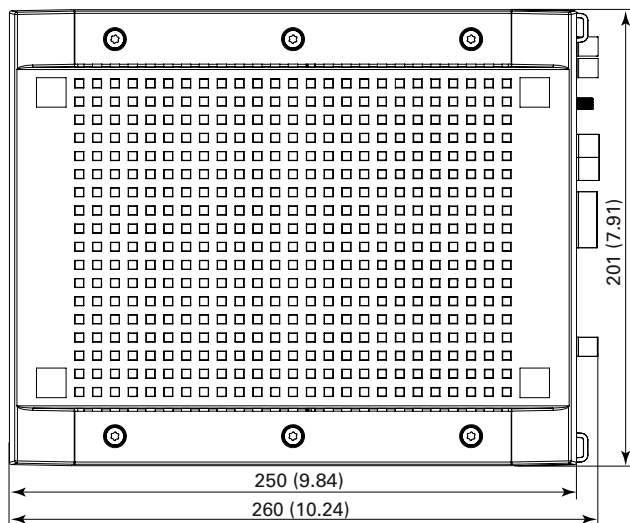
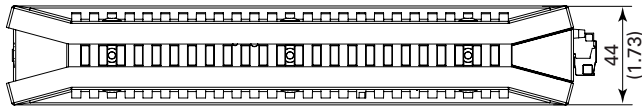

Mounting instructions

- Do not expose the amplifier to extreme temperatures (see “Technical data”).
- Observe the country-specific standards for installation, mounting and configuration.
- When opening the amplifier, ESD precautions must be observed.
- The amplifier may only be opened by authorised service engineers.

LED status indication

LED “Power” (front)

- Permanent green: main power supply applied
- Green blinking: power supply via PoE, no operation possible

LED “Fault” (front)

- Permanent red: short circuit at the low-resistance loudspeaker output
- Red blinking: loudspeaker line monitoring fault detected at the 70 V/100 V loudspeaker output

LED “Level” (rear)

- Red: too much amplification (clipping)
- Green/orange: amplification okay

Front view

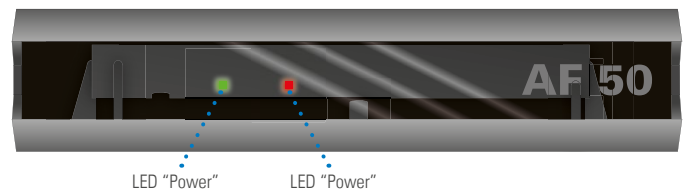

Rear view

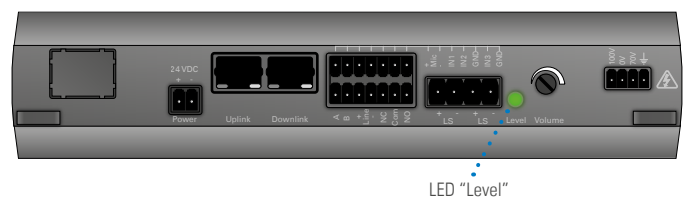

Connection

Connection diagram

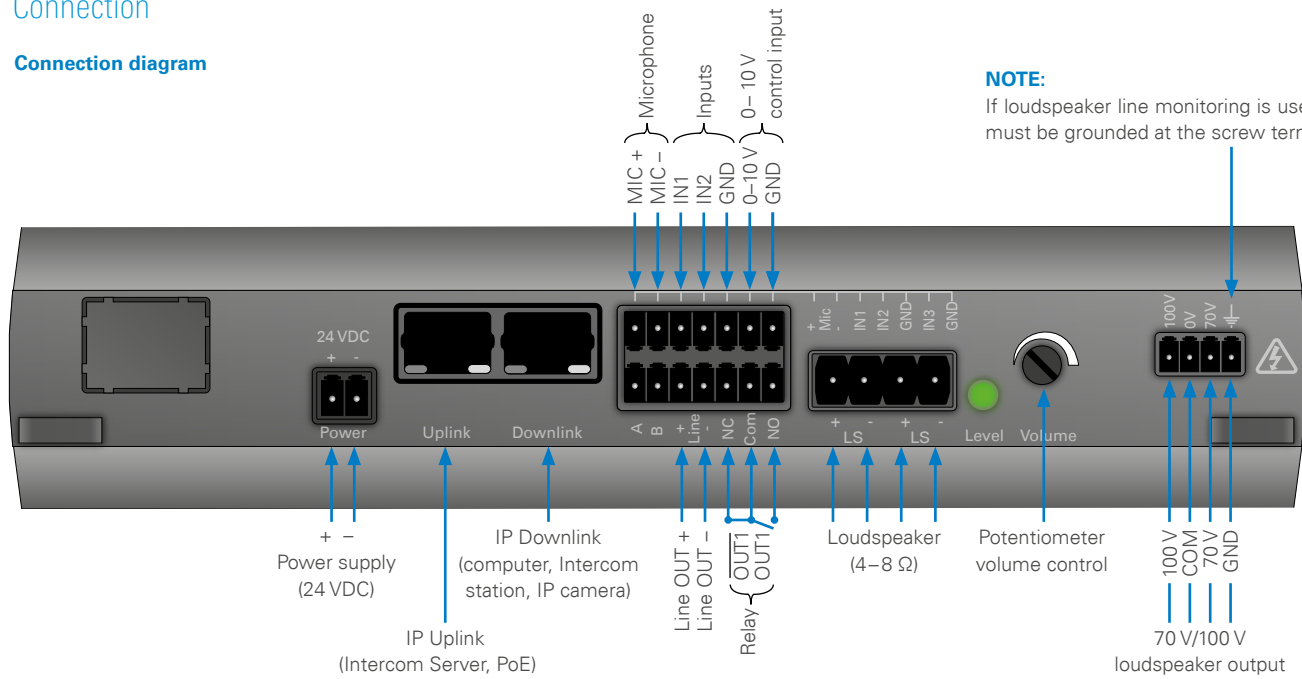

Connection loudspeakers

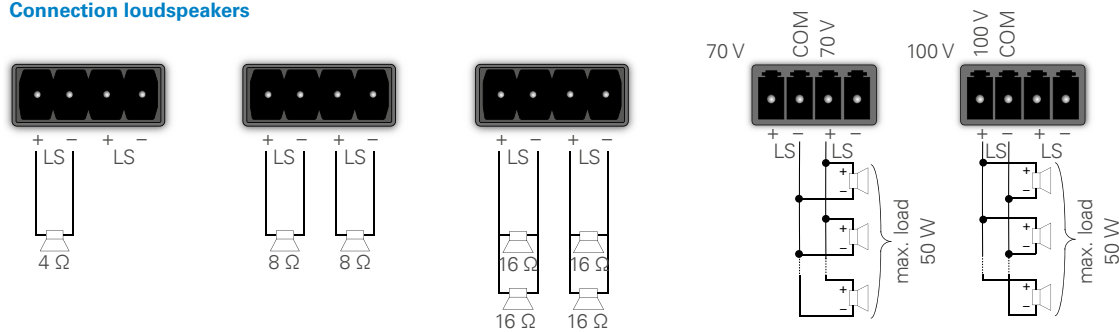

Volume settings

- The volume can be controlled via CCT 800 at **Subscriber > Audio - Features**.
- For loudspeaker line monitoring at the 70 V/100 V loudspeaker output, the potentiometer "Volume" has to be set to the maximum position.

Mounting

It is possible to mount the AF 501 via a wall and desk mount kit or a rack mount kit:

- Wall mount kit PF-WM (not included in extent of supply; for mounting, see short reference "PF-WM")
- Rack mount kit PF-RM (not included in extent of supply; for mounting, see short reference "PF-RM")

Connection and mounting of the expansion module EB2E2AHE

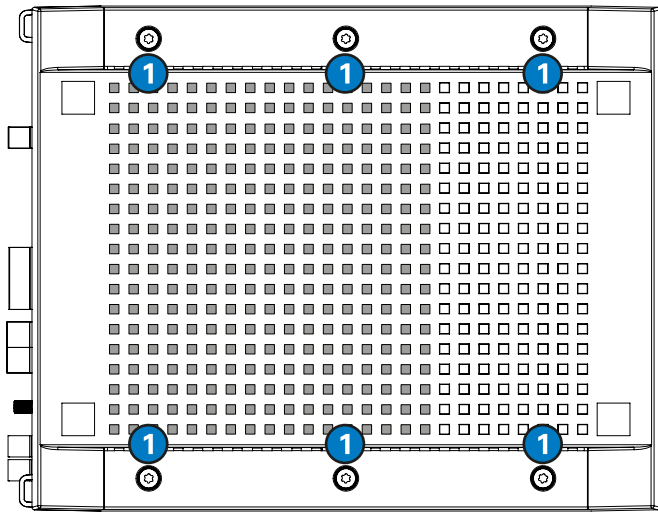

1 Remove the six screws at the top side, then remove the housing cover.

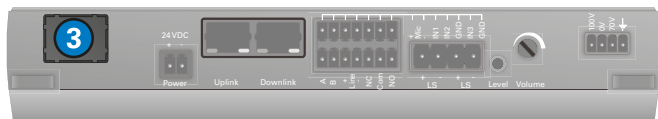

3 Break out the cover plate of the wiring hole.

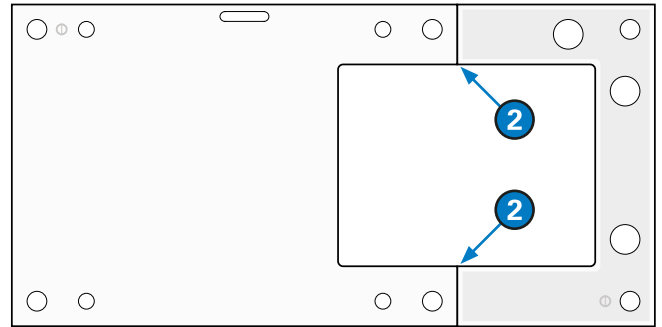

2 Shorten the EB2E2AHE at the break-off notches.

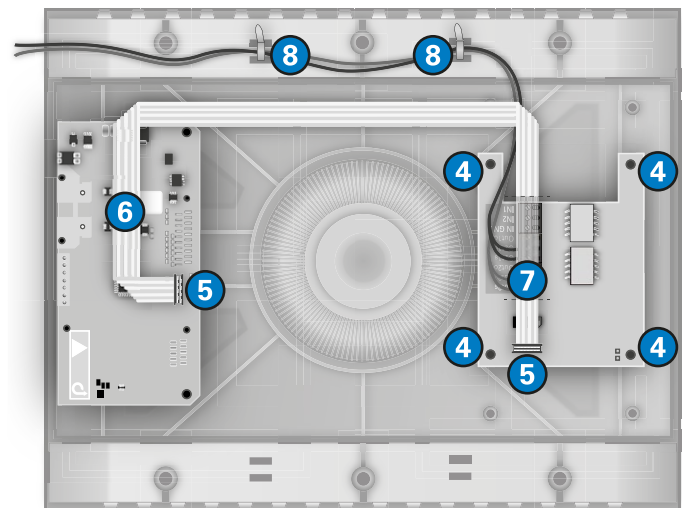

- 4** Screw the EB2E2AHE into the housing using the four 3 x 6 mm Torx cylinder head screws (included in extent of supply of the EB2E2AHE).
- 5** Connect the ribbon cable to the expansion jacks of the two PCBs (not included in extent of supply).
- 6** Install the ribbon cable as shown in the illustration.
- 7** Connect the required expansion cables to the screw terminals "IN" and "OUT".
- 8** Install the expansion cables as shown in the illustration and fix them using cable ties.
- 1** Mount the housing cover as shown in reverse order.

AF 50I

Loudspeaker line monitoring

Functionality

With the function loudspeaker line monitoring, it is possible to detect the following errors at the 70 V/100 V loudspeaker output:

- **Short circuit** (impedance < 100 Ω at 100 V/< 50 Ω at 70 V)
ATTENTION:
The loop resistance for the loudspeaker cable must be lower than 100 Ω so that a short-circuit can be detected.
- **Short circuit to ground** (impedance to ground < 50 kΩ)
- **Disconnection** (impedance > 10 kΩ at 100 V/> 5 kΩ at 70 V)
- **Impedance changing** (± 10%, ± 20%, ± 30%, ± 40% and ± 50%)

The loudspeaker line monitoring is based on an impedance measurement with adjustable tolerance values of ± 10%, ± 20%, ± 30%, ± 40% and ± 50%. These values prevent errors depending on changes in the temperature value, deterioration and so on. During the impedance measurement, a pilot signal (67 Hz with -23 dBFS) will be put out. The measurement is also carried out during audio output. An error is displayed with measurement cycles every 100 seconds.

System requirements

Hardware

- Amplifier AF 50I min. Rev. "AB"
- The amplifier must be grounded at the desired screw terminal.

Software

- Configuration software min. CCT 800 1.3 Serie
- Intercom Server software min. PRO 800 1.3 Serie
- Licence "L-AF-LM"

ATTENTION:

Loudspeaker line monitoring is not possible with the Intercom Server GE 700-UPG.

Configuration

ATTENTION:

For the configuration of the loudspeaker line monitoring, an active connection between CCT 800 and amplifier is required.

- Go to: **Subscriber > Station Properties > AF series > AF50 > tab Linemonitoring**
- Activate the checkbox **Line Monitoring**.
- In the drop-down list **Line**, select the used line type ("70 V" or "100 V").
- In the drop-down list **Tolerance**, select the tolerance value for measurements. Within this tolerance, a deviation from the reference value will not be interpreted as an error. It is recommended to set the tolerance value to 30%.
- Click on **Measure ...** to measure the impedance of the loudspeaker line (the measurement is displayed in the field "Impedance").
- Click on **Accept ...** to set the current measured value as nominal value (the current nominal value is displayed in the field "Impedance nominal value").
- Send the CCT 800 configuration to the Intercom Server.

Quality tested. Reliable. Smart.

COMMEND products are developed and manufactured by Commend International in Salzburg, Austria.

The development and manufacturing processes are certified in accordance with **EN ISO 9001:2015**.



The technical data contained herein has been provided solely for informational purposes and is not legally binding. Subject to change, technical or otherwise. lolP®, OpenDuplex® and Commend® are trademarks registered by Commend International GmbH. All other brands or product names are trademarks or registered trademarks of the respective owner and have not been specifically earmarked.

A strong worldwide network

COMMEND is represented all over the world by local Commend Partners and helps to improve security and communication with tailored Intercom solutions.

www.commend.com